

Projector Parts

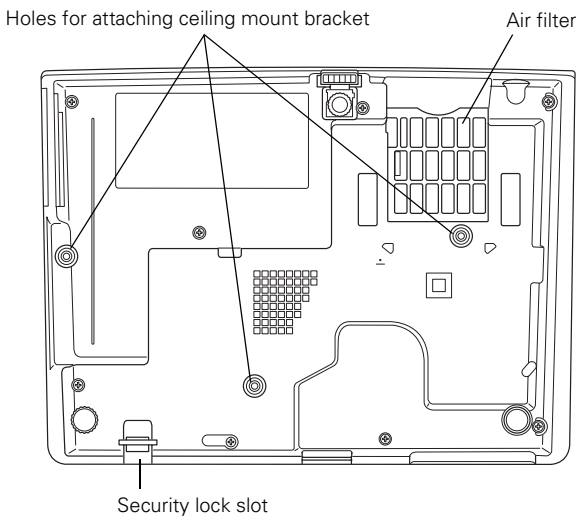

PowerLite S5 Series Control Panel

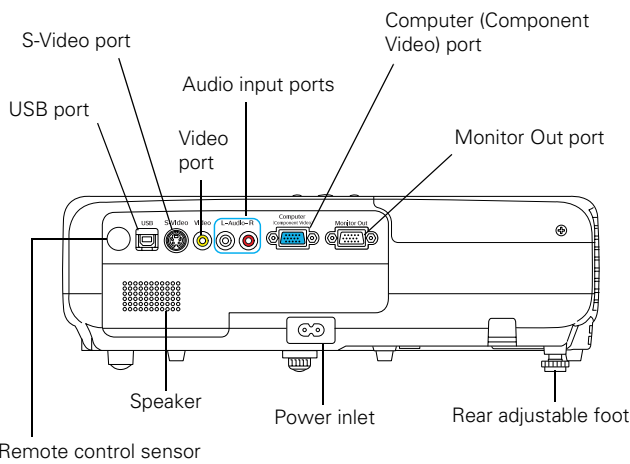
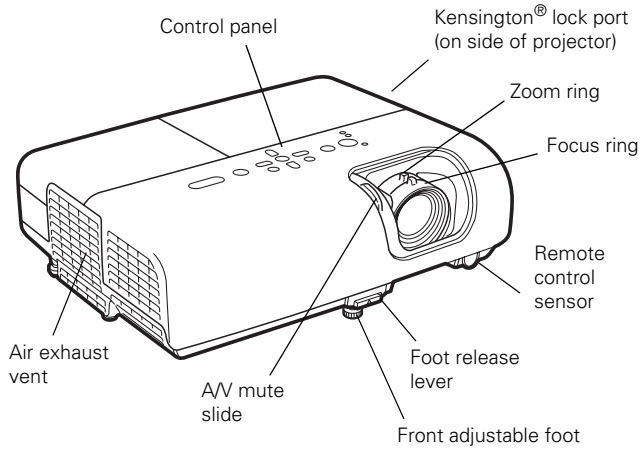
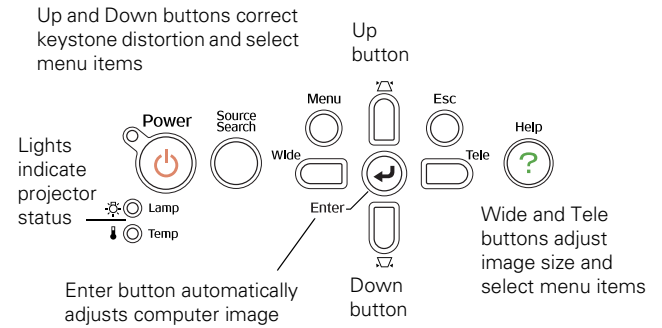

PowerLite 77c Control Panel

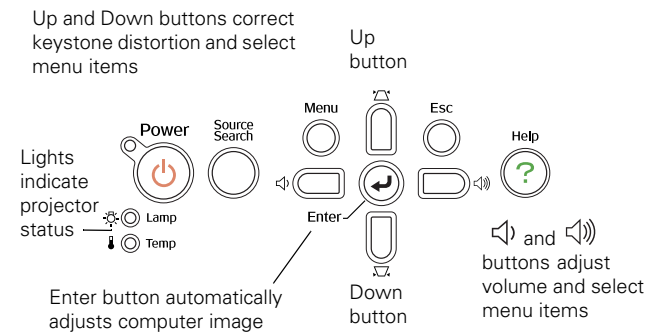

Projector Specifications

General

Type of display	Poly-silicon TFT active matrix
Lens	
PowerLite S5	F=1.44, focal length=16.6 mm
PowerLite 77c	F=1.6 to 1.74, focal length=18.4 to 22.12 mm
Resolution	
PowerLite S5	800 × 600 pixels (SVGA)
PowerLite 77c	1024 × 768 pixels (XGA)
Color reproduction	Full color, 16.77 million colors
Brightness (ANSI)	
PowerLite S5	2000 lumens (High brightness mode) 1600 lumens (Low brightness mode)
PowerLite 77	2200 lumens (High brightness mode) 1760 lumens (Low brightness mode)
Contrast ratio	400:1
Image size	30 to 300 inches

PowerLite S5 Series / 77c Projector

Projection distance	
PowerLite S5	2.9 to 39.8 feet (0.87 to 12.12 meters)*
PowerLite 77c	2.8 to 34.2 feet (0.84 to 10.42 meters)*

* Depending on tele and wide lens setting

Projection methods Front, rear, front ceiling, rear ceiling

Focus adjustment Manual

Zoom adjustment Digital (PowerLite S5)
Manual (PowerLite 77c)

Internal sound system 1 W monaural

Optical aspect ratio 4:3 (horizontal:vertical)

Zoom ratio
 PowerLite S5: 1:1.35 (digital)
 PowerLite 77c: 1:1.2 (optical)

Noise level 35 dB (High brightness mode)
28 dB (Low brightness mode)

Keystone correction angle $\pm 30^\circ$ vertical (maximum); $\pm 20^\circ$ in 16:9 aspect ratio
Automatic correction up to 11° on PowerLite 77c

Projection Lamp

Power consumption 170 W UHE

Lamp life About 3000 hours (High brightness);
4000 hours (Low brightness)

Note:

Lamp life results will vary depending upon mode selected, environmental conditions and usage. Lamp brightness decreases over time.

Remote Control

Range 20 feet (6 meters)

Batteries (2) Alkaline AA

Mouse Compatibility

Supports USB

Dimensions (including feet)

Height 4.25 inches (108 mm)

Width 12.9 inches (327 mm)

Depth 9.6 inches (245 mm)

Weight

 PowerLite S5 5.8 lb (2.6 kg)

 PowerLite 77c 6.0 lb (2.7 kg)

Electrical

Rated frequency 50/60 Hz

Power supply 100 to 120 VAC, 2.8 A
200 to 240 VAC, 1.2 A

Power consumption Operating: 248 W
Standby: 4.1 W

Environmental

Temperature Operating: 41 to 95 °F (5 to 35 °C)
Storage: 14 to 140 °F (-10 to 60 °C)

Humidity Operating: 20 to 80% RH,
non-condensing

Storage: 10 to 90% RH, non-condensing

Altitude Up to 4,900 feet (1,500 m)

Up to 7,500 feet (2,286 m) with high altitude mode enabled

Safety and Approvals

United States FCC Part 15B Class B (DoC)
UL60950-1

Canada ICES-003 Class B
CSA C22.2 No. 60950-1

CE Marking Directive 73/23/EEC, 89/336/EEC
IEC60950 Third Edition

Compatible Video Formats

You can use any of the following video sources: VCR, DVD player, camcorder, digital camera, or gaming console. The projector supports composite video, S-Video, component video, and RGB video, and it automatically senses the video format (HDTV, SDTV, NTSC, PAL, or SECAM).

The projector supports these international video standards:

Mode	Refresh Rate (Hz)
NTSC	60
NTSC 4:3	60
PAL	50
M-PAL	60
N-PAL	50
PAL60	60
SECAM	50
TV480i	60
TV576i	50 (PowerLite 77c only)
SDTV480p	60
SDTV576p	50 (PowerLite 77c only)
HDTV720p	60
HDTV720p	50 (PowerLite 77c only)
HDTV1080i	60
HDTV1080i	50

Compatible Computer Display Formats

To project images output from a computer, the computer's external monitor signal must be set at a refresh rate (vertical frequency) that's compatible with the projector; see the following table for compatible formats. For best results, the computer's resolution should be set to match the projector's native resolution; 800 × 600 (PowerLite S5) or 1024 × 768 (PowerLite 77c). If this resolution isn't available, select another compatible format.

Mode	Refresh Rate (Hz)	Resolution
VGA EGA	70	640 × 350
VGA—60	60	640 × 480
VESA—72	72	640 × 480
VESA—75	75	640 × 480
VESA—85	85	640 × 480
VGA—120 (PL 77c only)	120	640 × 480
SVGA—56	56	800 × 600
SVGA—60	60	800 × 600
SVGA—72	72	800 × 600
SVGA—75	75	800 × 600
SVGA—85	85	800 × 600
SVGA—120 (PL 77c only)	120	800 × 600
XGA—60	60	1024 × 768
XGA—70	70	1024 × 768
XGA—75	75	1024 × 768
XGA—85	85	1024 × 768
XGA—120 (PL 77c only)	120	1024 × 768
SXGA1—70	70	1152 × 864
SXGA1—75	75	1152 × 864
SXGA1—85	85	1152 × 864
SXGA1—100 (PL 77c only)	100	1152 × 864
SXGA2—60	60	1280 × 960
SXGA2—75	75	1280 × 960
SXGA2—85	85	1280 × 960
SXGA3—60	60	1280 × 1024
SXGA3—75	75	1280 × 1024
SXGA3—85	85	1280 × 1024
SXGA+—60	60	1400 × 1050
SXGA+—75	75	1400 × 1050
SXGA+—85	80	1400 × 1050
UXGA—60 (PL 77c only)	60	1600 × 1200
iMAC VGA (PL 77c only)	117	640 × 480
iMAC SVGA (PL 77c only)	95	800 × 600
iMAC XGA (PL 77c only)	75	1024 × 768
MAC13	67	640 × 480
MAC16	75	832 × 624
MAC19—60	59	1024 × 768
MAC19	75	1024 × 768
MAC21	75	1152 × 870

Positioning the Projector

Follow these guidelines to get the best results when projecting:

- ❑ Place the projector on a sturdy, level surface, between 3 and 34 feet (PowerLite 77c) or between 3 and 39 feet (PowerLite S5) from the screen.
- ❑ Make sure there is plenty of space for ventilation around and under the projector. Do not set the projector on top of loose papers that could block the vent under the projector.
- ❑ Make sure the projector is within 6 feet (1.8 meters) of a grounded electrical outlet or extension cord.
- ❑ Face the projector squarely toward the screen.

The projector supports 4 viewing setups, as shown below. If it is installed in a rear or overhead position, you need to select the correct projection option from the Extended menu after you turn it on.

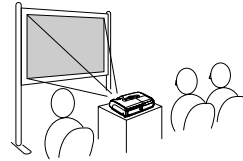
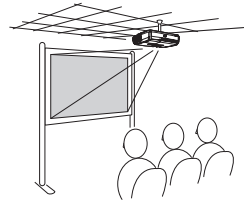
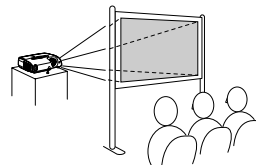

Table
Convenient for temporary front projection. Choose **Front** from the menu.



Front/Ceiling
Professional installation recommended. Choose **Front/Ceiling** from the menu.



Rear
For projecting behind a translucent screen. Choose **Rear** from the menu.

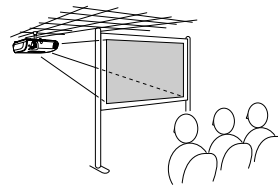

Rear/Ceiling
Professional installation behind a translucent screen recommended. Choose **Rear/Ceiling** from the menu.

If the projector is tilted in the front or the back, you may need to adjust the image shape. See page 7.

Image Size and Projection Distance

The distance between the projector and the screen determines the basic size of the projected image, as shown below. The diagrams show approximately how big your image will be, based on where you set up the projector. Because other adjustments—such as those made with the zoom ring—also affect the size of the image, the numbers shown in the illustration should be considered as general guidelines, not exact measurements.

PowerLite S5 Series

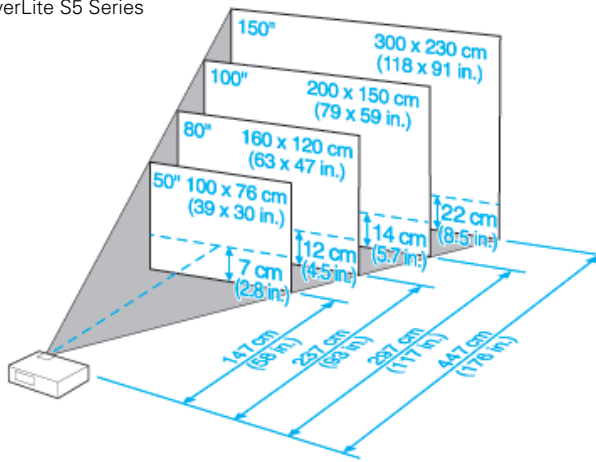

PowerLite 77c

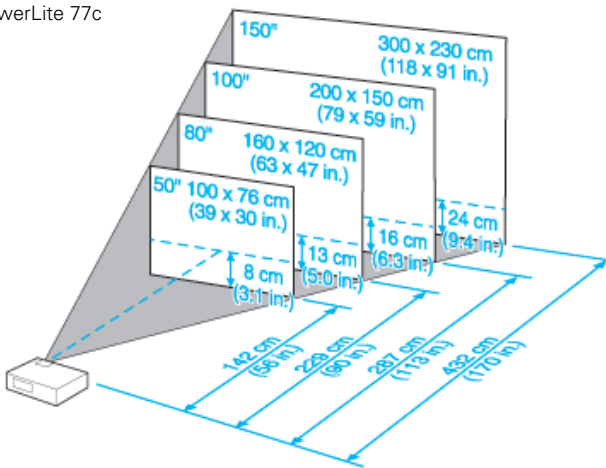

For more help determining the size of your image or where to position the projector, try the Image Size Calculator on the Drivers and Downloads page for your projector on Epson's website.

Turning On the Projector

Make sure your projector and other equipment are set up and connected correctly. Then turn on your projector, as described below.

If you turn on your connected computer or video equipment before starting the projector, the projector automatically detects and displays the image source. If you turn on the projector first, or have multiple pieces of equipment connected, you may have to select the image source manually. See "Adjusting the Image and Presentation" on page 7.

Follow these steps to plug in and turn on the projector:

1. Open the A/V Mute slide (lens cover).

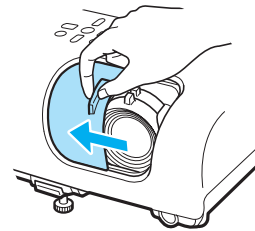

2. Connect one end of the power cord to the projector's power inlet.

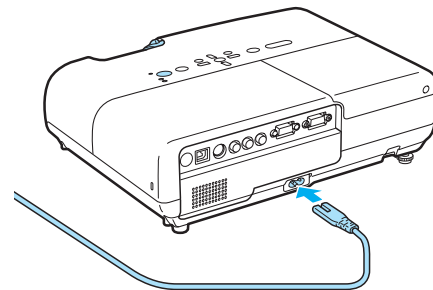

3. Connect the other end to an electrical outlet.

The power light on top of the projector turns orange, indicating that the projector is receiving power but not yet turned on.

4. Turn on your computer or video source if you have not already.

5. Press the  Power button on the projector or remote control to turn it on.

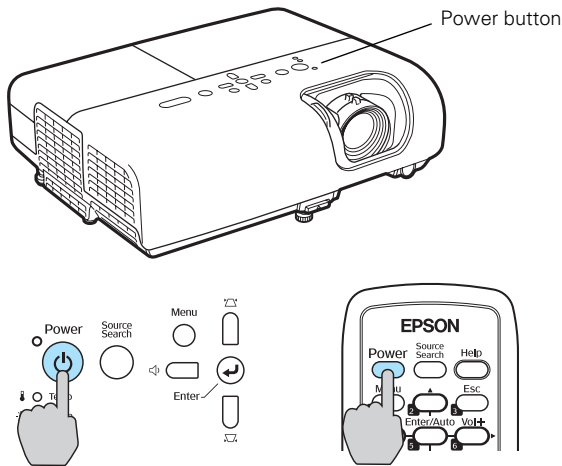

The projector beeps and the power light flashes green as the projector warms up. The projector lamp comes on in about 4 seconds and the power light stays green.

Warning:

Never look into the lens when the lamp is on. This can damage your eyes, and is especially dangerous for children.

- ❑ If you're using a computer, you should see your computer display projected after a moment or two. If not, you need to select the image source, as described in the next column.
(Windows only: If you see a message saying that it has found a plug-and-play monitor, click **Cancel**.)
- ❑ If you're projecting a video, you may need to press the **Source Search** button on the projector or remote control to switch to your video source. Then press the **Play** button on your DVD player or other device.
- ❑ If you are prompted to enter a password, enter it now.

To focus and adjust the image, see page 7. If a projected image fails to appear, see "What To Do If You See a Blank Screen" in the next column.

When you're done with your presentation, shut down the projector as described on page 6.

Selecting the Image Source

Selecting the image source lets you switch between images input from different pieces of equipment connected to the projector (such as a computer and DVD player). If you don't see the image you want, press the **Source Search** button on the remote control or projector until the correct device image is projected. (The name of the selected source appears in the upper right corner on the screen.)

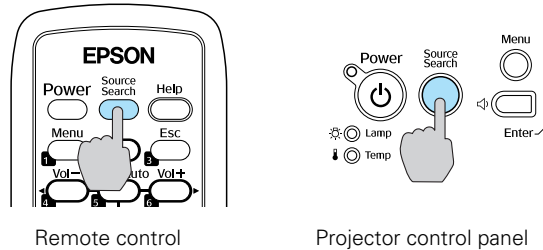

If a projected image fails to appear, see the next section for help.

What To Do If You See a Blank Screen

If you see a blank screen or a blue screen with the message **No Signal** after turning on your computer or video source, try the following:

- ❑ Make sure the cables are connected correctly to the selected input source.
- ❑ Make sure the power light is green and not flashing and the **A/V Mute** slide is open.
- ❑ Make sure you've selected the correct image source; see the previous section. Allow a few seconds for the projector to sync up after pressing the button.
- ❑ Check the projector's **Signal** menu to make sure the correct input source is selected. (See your *User's Guide* for more information.)
- ❑ Press the **Help** button on the projector or remote control and select "Image is not displayed" from the menu.

If you're using a PC laptop:

- ❑ Hold down the Fn key and press the function key that lets you display on an external monitor. It may have an icon such as  or it may be labelled CRT/LCD. Allow a few seconds for the projector to sync up after pressing it. Check your laptop's manual or online help for details.

On most systems, the  or CRT/LCD key lets you toggle between the LCD screen and the projector, or display on both at the same time.

- ❑ If you're projecting from a laptop, and you don't see the same image on the projection screen and computer screen, check your monitor settings to make sure both the LCD screen and the external monitor port are enabled.

From the Control Panel, open the Display utility. Click the Settings tab, then click Advanced. The method for adjusting the settings varies by brand; you may need to click a Monitor tab, then make sure the external Monitor port is set as your primary display and/or enabled. See your computer's documentation or online help for details.

If you're using a Macintosh laptop with OS X:

You may need to set up your system to display on the projector screen as well as the LCD screen. Follow these steps:

1. From the Apple menu, select System Preferences, then click Display or Displays.
2. Select VGA Display or Color LCD, click Arrange or Arrangement, and make sure Mirror Displays is checked.

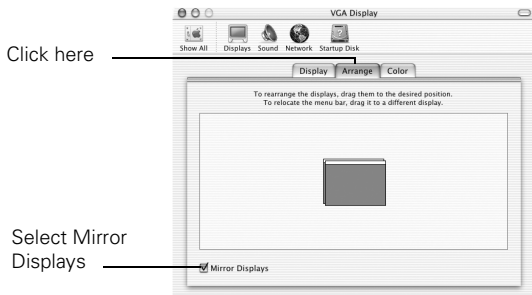

Turning Off the Projector

When you've finished using the projector, follow the recommended procedure to shut it down.

Note:

When sleep mode is enabled and the projector has not received any input signals for the number of minutes specified in the Extended menu (from 1 to 30), the projector automatically turns off the lamp and enters "sleep mode." This conserves electricity, cools the projector, and extends the life of the lamp. If you are done using the projector, unplug the power cord. If you want to start projecting again, plug it in and press the  Power button. You can turn sleep mode on or off through the Extended menu.

1. If you're using a computer, shut it down first; otherwise you may not be able to see your computer's display to shut it down properly.
2. To turn off the projector, press the  Power button on the projector or remote control.

You see this confirmation message: (If you don't want to turn it off, press any other button or wait a few seconds until it disappears.)

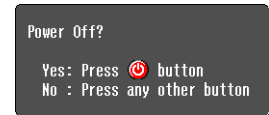

3. Press the  Power button again. The projector beeps twice, the lamp is turned off, and the power light turns orange.

Note:

With Epson's exclusive Instant Off[®] technology there's no cool-down period, so you can pack up and go immediately after turning off the projector.

If you want to turn the projector on again, press the  Power button.

4. Press up on the blue foot release lever and lower the projector to retract the front adjustable foot, if necessary.
5. Close the A/V Mute slide.
6. Unplug the power cord.
7. Turn off and disconnect any equipment plugged into the projector.

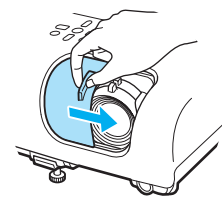

Caution:

To avoid damaging the projector or lamp, never unplug the power cord when the power light is green or flashing orange.

8. If you won't be using the projector for awhile, store it in the soft case that came with it or in a protective case.

Adjusting the Image and Presentation

The following sections describe how to adjust the image and control your presentation.

Focusing and Zooming Your Image (PowerLite S5 Series)

Rotate the focus ring to sharpen the image.

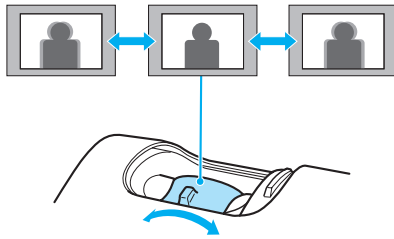

Press the Wide button on the projector to enlarge the image, or the Tele button to reduce it.

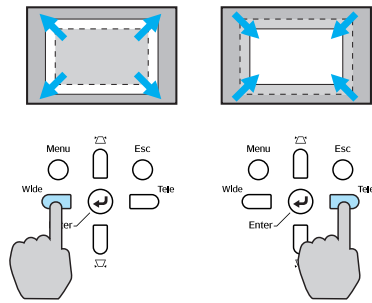

You can also change the image size by moving the projector closer to or farther away from the screen. You can use the E-Zoom buttons on the remote control to zoom in on a portion of the image. See page 9 for instructions.

Focusing and Zooming Your Image (PowerLite 77c)

Rotate the focus ring to sharpen the image, and the zoom ring to reduce or enlarge the image.

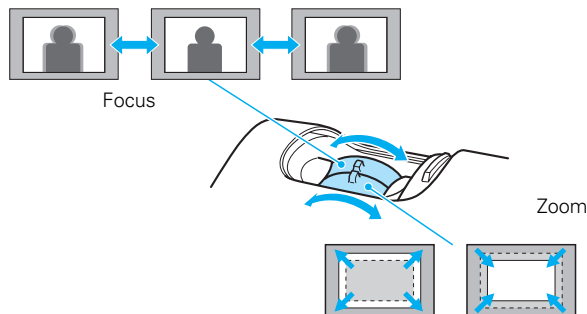

You can also change the image size by moving the projector closer to or farther away from the screen. You can use the E-Zoom buttons on the remote control to zoom in on a portion of the image. See page 9 for instructions.

Adjusting the Height of Your Image

If the image is too low, you can raise it by extending the projector's front adjustable foot.

1. Stand behind the projector. Press up on the blue foot release lever and lift the front of the projector to extend the front adjustable foot.

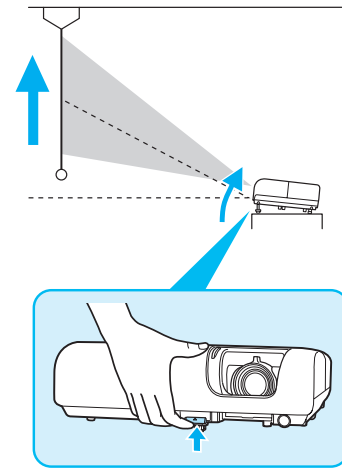

2. Once the image is positioned where you want, release the lever to lock the foot in position.

If the image is no longer rectangular after raising it, see the next section.



Adjusting the Image Shape

If the projector is tilted up or down, the images that are displayed will be distorted.

Note:

The PowerLite 77c automatically corrects images that are distorted when the projector is tilted up to 11° and can be corrected manually up to a 30° tilt. The Keystone window appears on the screen while the projector makes the correction. If the projected image still isn't rectangular, follow the instructions below.

To correct the distortion or "keystone" shape, do one or more of the following:

- ❑ If your image looks like  or , you've placed the projector off to one side of the screen, at an angle. Move it directly in front of the center of the screen, facing the screen squarely.

- ❑ If your image looks like or , you need to adjust the keystone correction value. Press the or buttons on the projector to correct the shape of the image. After correction, your image will be slightly smaller.

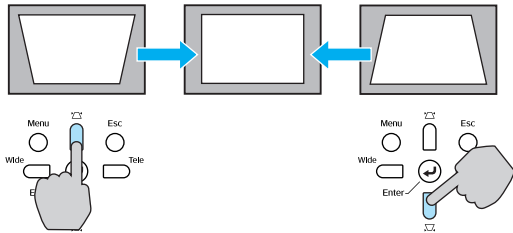

PowerLite S5 Series

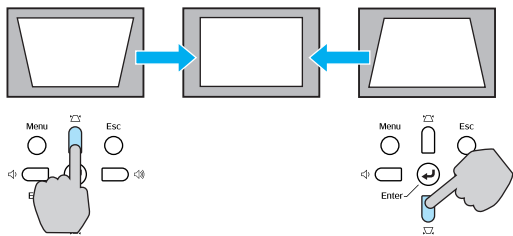

PowerLite 77c

- ❑ On the PowerLite 77c, you may need to turn on Auto Keystone in the Settings menu. See your *User's Guide* for instructions.

You can also make keystone adjustments using the projector's Settings menu, as described in the *User's Guide*.

Adjusting the Brightness

The brightness of an image depends on the source you are projecting and the amount of light in the room. If the image is too bright or not bright enough, here are two ways you can adjust it:

- ❑ Change the **Brightness** setting in the Image menu.
- ❑ Select **Low** or **High** for the **Brightness Control** option in the Settings menu. Low brightness mode extends the life of the lamp and decreases the fan noise.

Correcting Computer Images

If you've connected a computer and the image doesn't look right, or it doesn't fit properly on the screen, press the **Enter** button on the projector or the **Enter/Auto** button on the remote control. This automatically resets the projector's tracking, sync, resolution, and position settings. You must be projecting a computer image for this button to have any effect. Additionally, if the **Auto Setup** option in the Signal menu is set to **OFF**, the Auto function will not work.

Adjusting the Volume

You can use the **Vol-** and **Vol+** buttons on the remote control to increase or decrease the volume for the projector's built-in speaker.

Note:

You can also adjust the volume using the projector's Settings menu. See your *User's Guide* for details.

On the PowerLite 77c, you can also use the buttons on the projector to control the volume. Press the button to increase the volume, or the button to decrease it. A volume gauge appears on the screen while the volume is being adjusted.

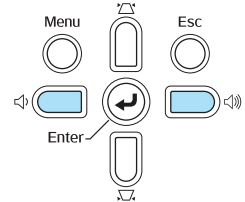
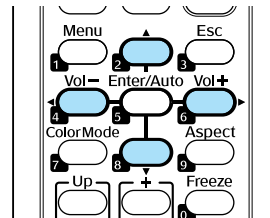

PowerLite 77c only

Note:

You must adjust the volume separately for each input source.

Adjusting the Color Mode

You may want to adjust the color mode to select a different setting that is appropriate for the image you're projecting and the environment in which you're projecting it. Press the **Color Mode** button on the remote control.

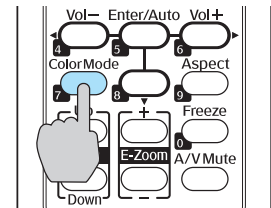

If you're projecting computer or RGB video images, the default color mode is **Presentation**, which is appropriate for full-color presentations in bright rooms.

The following table lists the color modes available.

Color mode	Description
Photo	Best for projecting still images with vivid color in a bright room (computer input only).
Sports	Best for watching TV in a bright room (component, S-video, or composite video input only).
Presentation	Use when you're projecting a full-color presentation in a bright room.
Text	Use when you're projecting a black and white presentation in a bright room.
Theatre	Use when projecting movies in a dark room.
Game	Brightest mode, best for use in a bright room.
sRGB	Use when projecting computer images conforming to the sRGB color standard.
Blackboard	Choose this fixed color mode when you need to project against a green chalkboard.

You can also use the projector menu system to change the color mode in the Image menu. (See the *User's Guide* for more information.)

Turning Off the Picture and Sound

Press the A/V Mute button on the remote control or use the A/V Mute slide on the projector to turn off the image and sound and darken your screen. This is useful if you want to temporarily re-direct your audience's attention without the distraction of a bright screen.

- ❑ To turn off the picture and sound, press the A/V Mute button or close the A/V Mute slide on the projector. The screen goes dark.

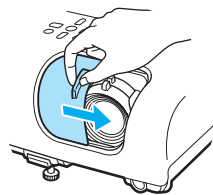
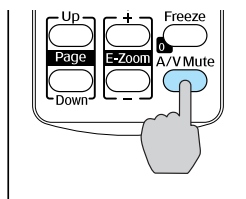

- ❑ To turn the image and sound back on, press the button again, or open the AV Mute slide.

You can create an image, such as a company logo or a picture, to display on the screen whenever you press the A/V Mute button. See your *User's Guide* for more information.

Stopping Action

Press the Freeze button to stop the action in your video or computer image and keep the current image on the screen. The sound will continue, however. Also, because the source continues to transmit signals, you won't resume the action from the point you paused it.

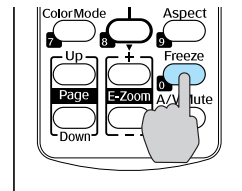

Press the Freeze button again to restart it.

Zooming Your Image

Follow these steps to zoom in on a portion of the image:

1. Press the E-Zoom + button on the remote control. You see a cross-hair indicating the center of the zoom-in area.
2. Use the four "arrow" buttons on the remote control to position the cross-hair in the area you want to enlarge.
3. Continue pressing the E-Zoom + button to enlarge the selected area up to 4 times. (Part of the image will be clipped when you zoom in.)
4. While the image is enlarged, you can:
 - ❑ Use the arrow buttons to pan about.
 - ❑ Press the E-Zoom - button to zoom out.
5. When you're done, press the Esc button to return to the original size.

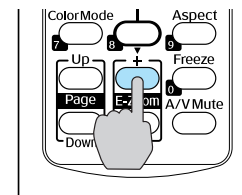

Changing the Image's Aspect Ratio

If you're projecting a widescreen format image, you can use the Aspect button on the remote control to change the aspect ratio. Follow the steps below.

Note:

You must be projecting component, composite, or S-Video images to change the aspect ratio.

1. Press the Aspect button once to change the aspect ratio to 16:9 for widescreen format.
2. Press it again to return to 4:3 aspect ratio.

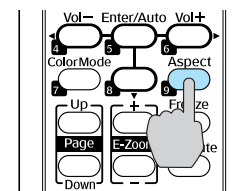

Note:

You can also change the aspect ratio using the projector's Signal menu. See your User's Guide for details.

Changing Presentation Slides

You can use the remote control to click through slideshow-style presentations (such as PowerPoint®) from up to 20 feet away. This gives you more flexibility, since you don't need to stand near your computer to change slides.

To change slides with the remote control, make sure you have connected your computer to the projector with a USB cable.

To advance slides in a PowerPoint presentation in Slide Show mode, press the Page up button on the remote control.

Press the Page down button to go back a slide.

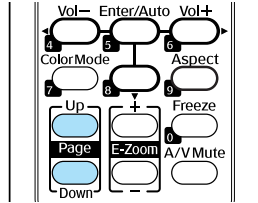

Note:

You cannot use the remote control as a mouse.

Projector Status Lights

The lights on top of the projector indicate the projector's status and let you know when a problem occurs.

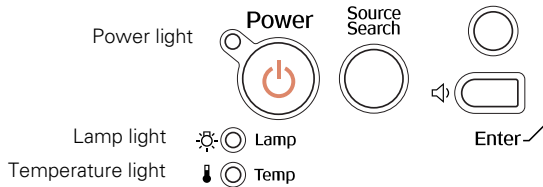

If the projector is not working correctly, first turn it off and unplug it. Then plug the power cord back in and turn on the projector. If this does not solve the problem, check the status lights on top of the projector and try the solutions recommended in the following table.

Power light	Lamp light	Temp. light	Description
Flashing red	Flashing red	Flashing red	There is an internal error in the projector. Turn the projector off and unplug it. Contact Epson for help.
Red	Off	Flashing red	There is a problem with the fan or a sensor. Clean the air filter and air vents. If this does not solve the problem, turn the projector off and unplug it. Contact Epson for help.

Power light	Lamp light	Temp. light	Description
—	Flashing orange	Off	Replace the lamp with a new one as soon as possible. If you continue to use the lamp, there is a risk it may break.
Red	Flashing red	Off	The lamp is burned out, broken, or not installed correctly; or the lamp cover is open. Close the cover or replace or reset the lamp, if necessary. Also, clean the air filter and air vents. If you are using the projector at an altitude above 4900 ft (1500 m), turn on High Altitude mode as the Operation setting in the Extended menu. If these suggestions don't work, contact Epson.
Red	Off	Red	The projector has overheated and turned itself off. Let it cool for about five minutes, then turn it back on. Make sure there is plenty of space around and under the projector for ventilation. Also clean the air filter and air exhaust vents. If it continues to overheat, you may need to replace the air filter.
Red	Off	Flashing orange	The projector is too hot. Make sure the temperature surrounding the projector does not exceed 95 °F (35 °C) and there is plenty of space around and under the projector for ventilation. Clean the air filter and air vents, if necessary. See page 12 for instructions.
Flashing orange	Off	Off	The projector is shutting down. Wait for the light to stop flashing and remain orange before unplugging it.
Orange	Off	Off	The projector is in standby or sleep mode. You can unplug it or press the Power button to turn it on.
Flashing green	Off	Off	The projector is warming up. Wait for the image to appear.
Green	Off	Off	The projector is operating normally.

Using the Remote Control

The remote control uses a line-of-sight infrared signal. It lets you access the projector's features from anywhere in the room—up to 20 feet away. (This distance may be shorter if the remote control batteries are low.)

The projector may not respond to remote control commands in these conditions:

- ❑ You are too far away—not within 20 feet (6 meters)—or not within 30° to the left or right of the front or rear sensor or 15° above or below it
- ❑ The battery is weak or not installed correctly
- ❑ Ambient light is too bright
- ❑ A fluorescent light is shining into the infrared receiver
- ❑ A strong light source (such as direct sunlight) shines into the infrared receiver
- ❑ Other equipment emitting infrared energy is present (such as a radiant room heater)
- ❑ If a button on the remote control has been held for more than 30 seconds, the remote enters sleep mode. Press another button for normal operation.

Remote Control Buttons

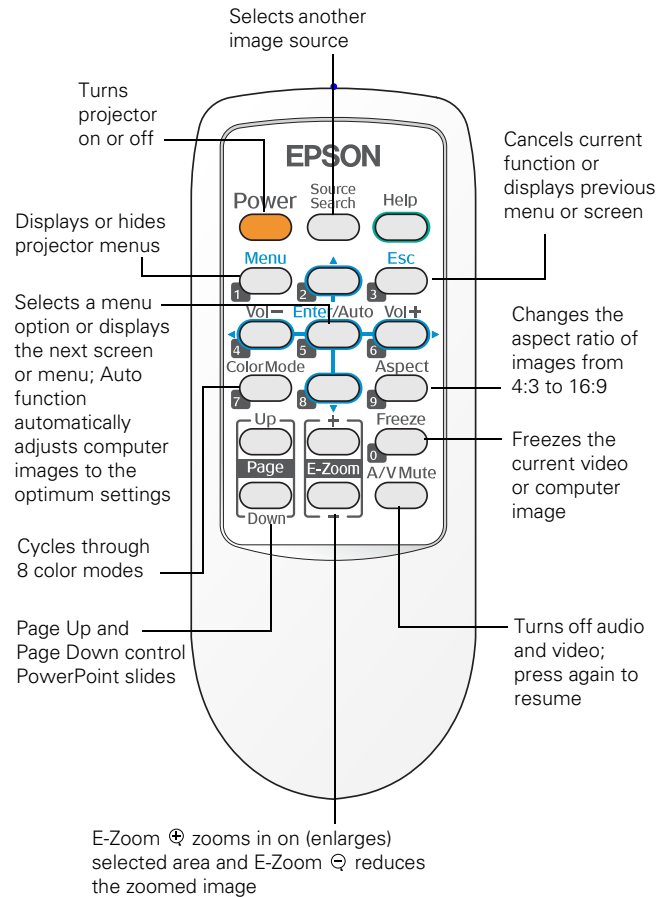

Replacing Remote Control Batteries

When the batteries run out, follow the steps below to replace them. The remote requires two AA alkaline batteries.

Note:

The remote control automatically shuts off when it detects a button being pressed for more than 30 seconds. This conserves battery life. It can be helpful, for example, when the remote is in a carrying case and the Power button is accidentally pushed.

Caution:

When replacing batteries, take the following precautions:

- ❑ Replace the batteries as soon as they run out. If a battery leaks, wipe away the battery fluid with a soft cloth. If fluid gets on your hands, wash them immediately.
- ❑ Do not expose batteries to heat or flame.
- ❑ Dispose of used batteries according to local regulations.
- ❑ Remove the batteries if you won't be using the remote control for a long period of time.

1. Press in the tab to remove the battery cover.

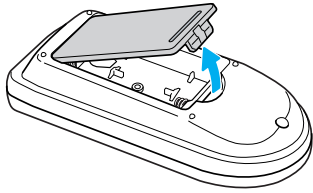

2. Remove the old batteries, then insert the new ones as shown.

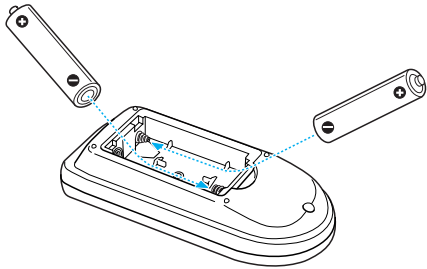

3. Replace the battery cover. Make sure it clicks into place.

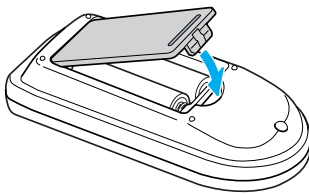

Cleaning the Projector Case

Before you clean the projector case, turn off the projector and unplug the power cord.

- ❑ To remove dirt or dust, wipe the outside with a soft, dry, lint-free cloth.
- ❑ To remove stubborn dirt or stains, moisten a soft cloth with water and a mild detergent. Then wipe the case.

Caution:

Do not use wax, alcohol, benzene, paint thinner, or other chemicals. These can damage the case.

Cleaning the Lens

Clean the lens whenever you notice dirt or dust on the surface.

- ❑ Use a canister of compressed air to remove dust.
- ❑ To remove dirt or smears on the lens, use lens-cleaning paper. If necessary, moisten a soft cloth with lens cleaner and gently wipe the lens surface.

Caution:

Do not use glass cleaner to clean the lens; this will damage the lens coating.

Cleaning and Replacing the Air Filter

Your projector includes an air filter to ensure the best performance. If dust collects on the air filter or vent on the bottom of the projector, clean them as described below. Dust clogs prevent proper ventilation and can cause overheating and damage the projector.

When the filter and vent are clogged, the projector displays the message **The projector is overheating**. Make sure nothing is blocking the air vent, and clean or replace the air filter.

To clean the air filter and air intake vent, follow these steps:

1. Turn off the projector, allow it to cool down, and unplug the power cord.
2. To clean the filter and vent, Epson recommends using a small vacuum cleaner designed for computers and other office equipment. If you don't have one, gently clean them using a very soft brush (such as an artist's paintbrush).

You can remove the air filter to clean both sides.

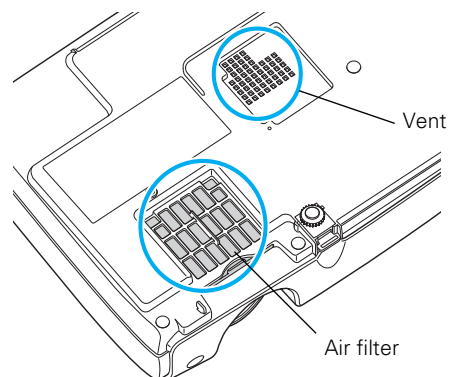

If the dirt is difficult to remove or if the filter is torn, replace it. Contact your dealer or call Epson at (800) 463-7766 to obtain a new one (part number V13H134A13).

3. If you need to clean or replace the filter, slide it out, as shown.

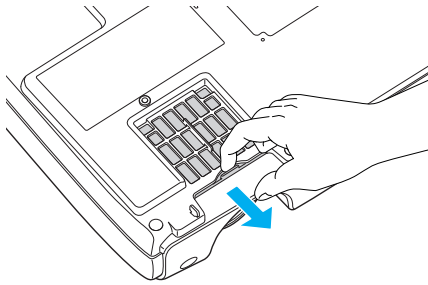

4. Align the new filter carefully and slide it in until it clicks into place.

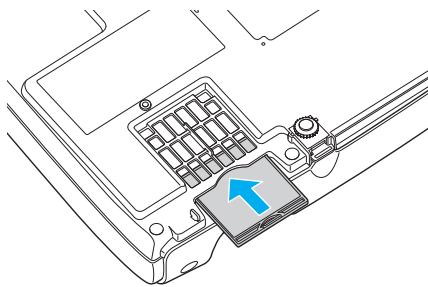

Note:

Air filters contain polycarbonate, ABS resin, and polyurethane foam. Dispose of used air filters according to local regulations.

Replacing the Lamp

The projection lamp typically lasts for about 3000 hours of use (in high brightness mode) or 4000 hours (in low brightness mode). It is time to replace the lamp when:

- ❑ The projected image gets darker or starts to deteriorate.
- ❑ The  lamp light is flashing orange.
- ❑ The message **Replace the Lamp** appears on the screen when the lamp comes on. To maintain projector brightness and image quality, replace the lamp as soon as possible.

Note:

You can check to see how many hours the lamp has been used through the Info menu.

Contact your dealer or call Epson at (800) 463-7766 for a replacement lamp. Request part number V13H010L41.

Warning:

Let the lamp cool before replacing it. If the lamp breaks, handle the shards carefully to avoid injury.

Follow these steps to replace the lamp:

1. Press the  Power button twice to turn off the projector. When you hear the projector beep twice, unplug the power cord.
2. If the projector has been on, allow it to cool down for at least an hour (or until the lamp is cool).
3. Use the screwdriver included with the replacement lamp to loosen the screw holding the lamp cover (the lamp cover is located on top of the projector).
4. Slide the cover out, then lift it off.

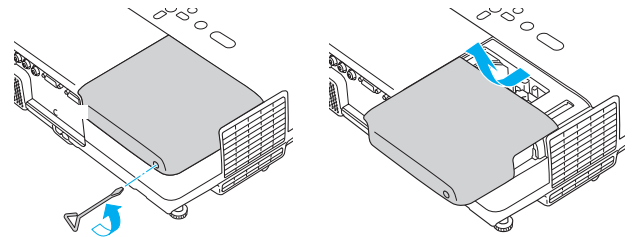

5. Use the screwdriver to loosen the two screws holding the lamp in place. (You can't remove the screws.)

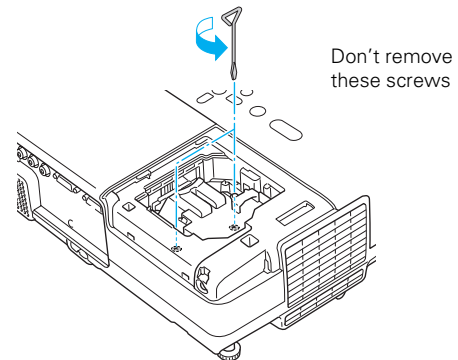

6. Hold the lamp as shown and pull it straight out.

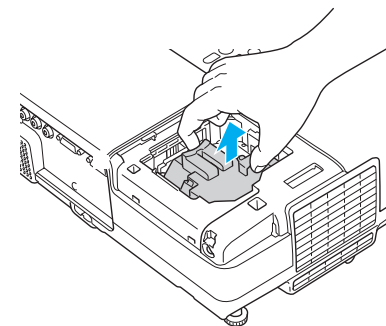

Note:

 *The lamp(s) in this product contain mercury. Please consult your state and local regulations regarding disposal or recycling. Do not put in the trash.*

7. Gently insert the new lamp along the guide rail. If it doesn't fit easily, make sure it's facing the correct way. Push the lamp down firmly where the label **PUSH** appears.

Caution:

Do not touch the glass portion of the lamp assembly. Touching the glass could result in premature lamp failure.

8. Once the lamp is fully inserted, tighten its screws.
9. Lower the lamp cover into place. (The opening should be almost covered, and the top of the cover should be flush with the top of the projector.) Then slide the cover closed and tighten the screw.

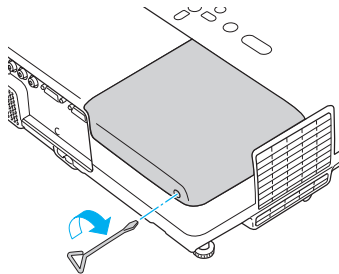

Note:

Be sure to seat the lamp fully and secure the lamp cover. If the lamp is not properly installed or the cover is loose, the lamp will not turn on.

10. Reset the lamp timer as described in the next section.

Resetting the Lamp Timer

You must reset the lamp timer after replacing the lamp to clear the **Replace the Lamp** warning message. Follow the steps below.

Note:

Do not reset the lamp timer if you have not replaced the lamp. If you do, the Lamp Hours will not accurately reflect the number of hours that the lamp has been used.

1. Connect the power cable and turn on the projector.

2. Press the **Menu** button on the remote control or projector and select the **Reset** menu. Then press **Enter**. You see the following:

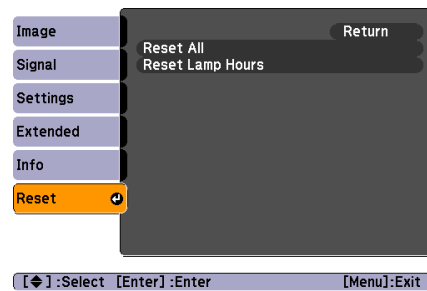

3. Select **Reset Lamp Hours** and press **Enter**. You see a confirmation screen.
4. Select **Yes** and press **Enter**.
5. Press **Esc** to return to the main menu or the **Menu** button to exit the menu system.

Transporting the Projector

The projector contains many glass and precision parts. If you need to transport it, please follow these packing guidelines to prevent damage to the projector:

- When shipping the projector for repairs, use the original packaging material if possible. If you do not have the original packaging, use equivalent materials, placing plenty of cushioning around the projector.
- When transporting the projector as freight or checked luggage, first put it in the supplied carrying case, then pack it in a firm box, using cushioning around the case.
- When you are hand-carrying the projector, be sure to use the supplied carrying case.

Note:

Epson shall not be liable for any damages incurred during transportation.

Optional Accessories

You can purchase the following optional accessories from an Epson authorized reseller. To find the nearest reseller, call 800-GO-EPSON (800-463-7766). Or you can purchase online at www.epsonstore.com (U.S. sales) or www.epson.ca (Canadian sales).

Product	Product number
Replacement lamp	V13H010L41
Air filter set (includes 2 filters)	V13H134A13
Component video to VGA (HD15) cable S-Video cable	ELPKC19 ELPSV01
Distribution amplifier	ELPDA01
Duet™ portable projector screen 50-inch portable screen 60-inch portable pop-up screen 80-inch portable pop-up screen 83.6-inch hanging pull-down screen	ELPSC80 ELPSC06 ELPSC07 ELPSC08 ELPSC09
ELPDC05 high resolution document imager	V12H162020
Kensington security lock	ELPSL01
Ceiling mount (gyro lock with suspension adapter) False ceiling plate Suspension adapter Security bracket/cabling for gyro lock mounts Adjustable ceiling channel	ELPMBUNI ELPMBFCP ELPMBAPL ELPMBSEC ELPMBACC
Presentation remote control kit	ELPST09B

Note:

To purchase a replacement remote control, call (562) 276-4394 (U.S.) or (905) 709-3839 (for dealer referral in Canada).

Related Documentation

CPD-23268	<i>PowerLite S5 Series / 77c Quick Setup</i> (English)
CPD-23324	<i>PowerLite S5 Series / 77c Installation rapide</i> (French)
CPD-23325	<i>PowerLite S5 Series / 77c Guide de instalación</i> (Spanish)
CPD-23326	<i>PowerLite S5 Series / 77c Guia de instalação</i> (Portuguese)
CPD-23258R2	CD-ROM containing the <i>PowerLite S5 Series / 77c User's Guide</i> in English, French, Spanish, and Portuguese